

R310

Laser Receiver

Instruction Manual



Instruction Manual – English

Laser Receiver R310 (BG 830140/1)

Software Version V 6.00

We would like to congratulate you on the purchase of your Status Pro R310 Laser receiver. Before initial usage you should carefully read the safety instructions as well as the user guidelines contained in this manual. We wish you every success when using this Measurement Instrument.

Please note: User Manuals can be amended when improvements or changes to the product range have been carried out. Use the link below to make sure you have the most up to date version of your User Manual: www.statuspro.com/machine_geometry/documents/.

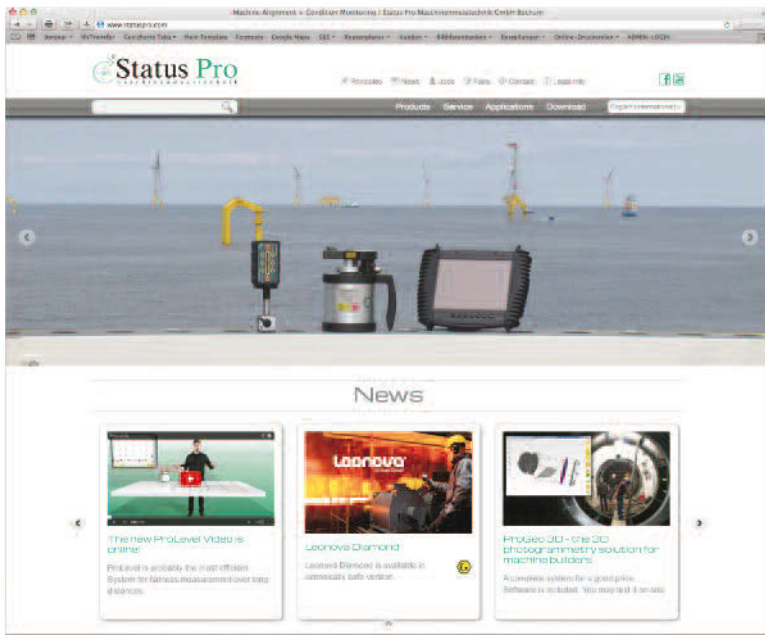

Content

1. SAFETY INSTRUCTIONS	4
1.1 Class of Laser	4
1.2 Standards	5
1.3 Advice on batteries / rechargeable cells	5
1.4 Instrument care	6
1.5 Maintenance	6
1.6 Calibration and repair	7
1.7 Liability Exclusion	7
2. GETTING STARTED	8
2.1 Power supply	8
2.2 Assembly	9
3. OPERATION	10
3.1 Control and information elements of the R310	10
3.2 R310 keypad	11
3.3 Setup Menu of the R310	12
3.4 Display features of the R310	13
4. MEASUREMENT	14
4.1 Signalling	14
4.2 Distance and Averaging	14
4.3 Remotely controlling the Laser using Infra-red	15
4.4 Achieving a level plane using Infra-red	15
4.5 Measuring objects of different height	16
4.6 Checking and calibrating the self-levelling feature of the T330 Laser	17
5. TECHNICAL DETAILS	19
6. ACCESORIES	20

1. Safety instructions

1.1 Class of Laser

The laser light emitted from a Status Pro Laser has an Output Rating of $< 1,0$ mW. The Laser is placed in the category „Class 2“ and is classified as safe for the use as a Measurement instrument. There are however a few safety aspects to be observed:



Caution!

- Do not stare into the laser beam.
- Do not point the laser beam at other people.
- Observe the local safety guidelines on Site and if in doubt consult the Site safety Engineer.
- Do not use the equipment in damp or moist locations.
- Ensure shading of the equipment against direct sunlight or heat sources.
- Fluids or rain as well as extreme temperature conditions may damage the equipment.



Note

Do not violently shake the Laser or other sensors and always protect against falls. This can damage the structure or the optics of the instrument resulting in false measurements.
Do not touch rotating parts when in use!

1.2 Standards

All Status Pro Laser and Receiver Instruments are developed and manufactured according to the following CE Standards:

**BG 830134, BG 830136, BG 830930,
BT 800072, BT 800071**

- EN 61326-1:2013
- EN 61000-3-3:2006 + A1:2009 + A2 2009
- EN 61000-3-3:2013

BG 830135

- RE 2014/53/EC
- EN 300328 V1.9.1
- EN 301489-1 V1.9.2
- EN 301489-17 V2.2.1
- EN 61000-6-2:2005



1.3 Advice on batteries / rechargeable cells

If the equipment is being stored for a longer period of time or being powered using Mains, then the batteries should be removed to prevent damage of the instrument through leakage.

When using rechargeable cells always observe the specific charging procedures for the cells.

Rechargeable cells can be recharged around 1000times when treated correctly, but there is no guarantee!



Caution!

Do not try to recharge normal batteries. Do not expose batteries or rechargeable cells to fire or excess heat (Danger of explosion).
Do not mix batteries and rechargeable cells.
Always use batteries and cells of the same kind.
Do not mix old and new batteries or cells.

**Note**

Help to protect the environment! Empty batteries do not belong in the household waste disposal system. Only deposit empty or damaged cells at a collection point specially designed for this purpose.

1.4 Instrument care

Your measurement instrument is designed for use in an industrial environment and can withstand water splashes or light spray as well as dust. Clean the equipment using a soft cotton cloth and a mild soap solution. Laser apertures as well as sensor areas should only be cleaned using a soft, dry and dust-free cloth. Do not use paper towels to clean glass surfaces as they could scratch. Avoid contact with grease, oil or oil-based solutions when handling the equipment.

1.5 Maintenance

The mechanical components of your equipment are prone to natural wear and tear! If the Instrument appears to have a technical defect, contact the Manufacturer. Do not try to repair or open the sensor casing. Attempted repairs through unauthorised personnel makes the guarantee null and void! Always store the equipment under dry conditions and use the case for transportation.

To ensure trouble-free processing, simply fill in the form you will find using the following link: http://www.statuspro.com/service/repair_and_calibration/.

**Advice**

To be able to identify the equipment when seeking advice always quote the serial number of the equipment. The Manufacturer does not accept any responsibility for damage incurred through incorrect maintenance carried out by non-authorised personnel.

1.5 Calibration and repair



To guarantee measurement accuracy, and reliable operation of your Status Pro Measurement System, it is of utmost importance that the recommended Service Intervals be adhered to. The System should be checked for serviceability, and re-calibrated by the Status Pro workshops every 12 months.

Within the scope of the service checks, the complete system will also be examined for possible wear or damage, as well as receiving any software updates. The date of the next service check for your equipment is stamped on the Status Pro calibration sticker.

To ensure trouble-free processing of the service and calibration checks, simply fill in the form you will find using the following link:

http://www.statuspro.com/service/repair_and_calibration/.

1.6 Liability Exclusion

The Status Pro GmbH does not accept responsibility for damage incurred through incorrect use or handling of the equipment. To ensure correct usage, a founded knowledge of the equipment is essential. It is of the utmost importance that you read and understand the Handbook!

No responsibility will be accepted for damage incurred through ignorance or disregarding of the operating instructions.

2. Getting started

The R310 is made up of two „housings“: the Instrument part (I) which contains the electronics and the sensor itself, and the Battery pack (II) which contains the power supply.

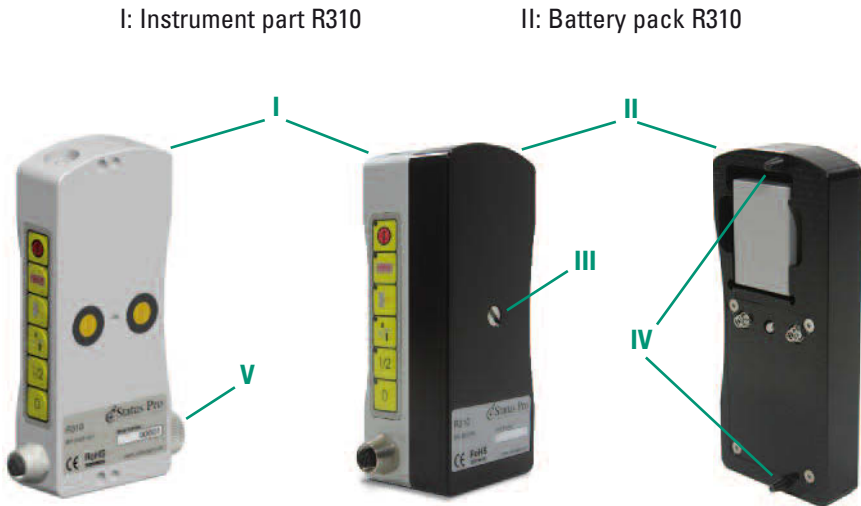

2.1 Power supply

Battery-powered operation

If, when turning on the Sensor (see Chapter 2), nothing is visible in the Display or if this symbol is visible: **bAtE** then new or fresh batteries should be inserted.

To replace the batteries, simply loosen the fixing screw (III) then separate the two housings.

Observe the following carefully:

- Ensure correct polarity when inserting the batteries
- Only use Alkaline batteries (AA) or NiMh. rechargeable cells, (AA) or Mignon
- When storing the Sensor for longer periods, remove the batteries to prevent leakage and/or corrosion

Set values and preferences remain stored during battery changes.

Ensure correct alignment of the guide pins (IV) and holes when remounting the battery pack, as this ensures correct polarity.

Mains operation

Alternatively, the R310 can be powered using a suitable mains supply and the cable group BT800066 (optional extra). The cable uses a threaded connector for the sensor side; ensure correct mounting of the connector with the sensor.

Usage of a mains power supply makes sense when carrying out long-term measurements or when being used as a permanent monitoring sensor. Furthermore, when the R310 sensor is being powered using Mains, the battery housing can be dismantled which is useful in tight situations.

2.2 Assembly

The R310 Laser Receiver has a hole on the underside allowing sensor mounting using the BT 948336 M8 Adapter.

When the sensor has been mounted onto the adapter, the knurled screw (V) can be tightened ensuring exact and reproduceable positioning of the sensor.

To enable othogonal positioning of the R310 sensor to the laser, simply loosen the knurled screw (V), turn the sensor as required and tighten the knurled screw again. Tightening the



Adapter M8
(BT 948336)



knurled screw ensures the correct height positioning! The measurement Adapter also has an M8 thread which facilitates the mounting of the sensor using a block magnet (BT 943092) or on any other suitable attachment with an M8 thread. The measurement adapters are often used as a permanently fixed attachment on for example buildings or large machines enabling the measurement and documentation of any changes in the structure over a long period of time.

Furthermore, the R310 has four M4 threaded holes, two on the front face of the sensor (VI) and two on the back of the battery housing (VII). The sensor can be mounted directly on the measurement object using the threaded holes or using a suitable adapter.

3. Operation

3.1 Control and information elements of the R310:

- A) Display
- B) Laser aperture
- C) Laser position and "set" LEDs
- D) Fixing screw
- E) Spirit level
- F) Set-up keypad
- G) Infra-red apertures
- H) Bluetooth and Power Signal (only BG 830135)
- I) Power and data socket

The rotating laser beam travels through the Aperture (B) and strikes the detector. A value is produced which is displayed over the Display (A).

The Laser position LEDs (C) show if the Laser beam is above or below the Zero line. Using the spirit level (E), the R310 can be vertically adjusted to ensure an orthogonal alignment of the sensor to the Laser.

All the necessary settings and parameters can be set up using the keypad (F).

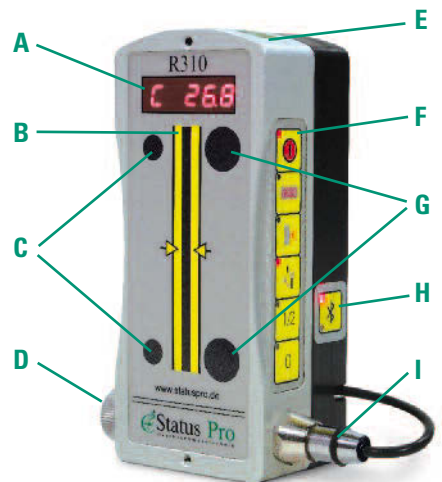

3.2 R310 keypad:

1) **ON/OFF, Escape from the Menu**

Use the Power button (1) to turn the sensor on and off.

Furthermore, this button is used to exit the Menu.

2) **Display ON / OFF**

The Display Button (2) is used to turn off the display when measuring over long periods of time to save battery power.

To turn back on simply press again.

3) **Infra-red control ON / OFF**

The IR Button (3) activates the Infra-red mode. The mode of control has to be chosen from the Menu. IR Control deactivation through repeated pressing.

4) **Menu / Toolbox**

Press the Menu button(4) repeatedly to toggle through the Set-up Menu (see Chapter 3.3).

5) **Halving**

Pressing the Halving button(5) divides the displayed value by two. Pressing again for longer than 1 second returns the full value.

6) **Zeroing / Set**

To „zero“ the displayed value, simply press the Zero/Set button(6). This is useful when aligning the Laser to a reference object (see Chapter 4 – Measurement).

The “native Zero” of the sensor is returned when the Zero button(6) is pressed for longer than 1 second.

The Zero/Set button (6) is also used to set a chosen parameter within the Menu.

7) **Bluetooth**

Bluetooth can be switched on and off by the Bluetooth button (press 1 second).

Operation is shown by the red LED. A Bluetooth connection is indicated when the blue LED is blinking. (For Bluetooth the R310 has to be connected by cable!)

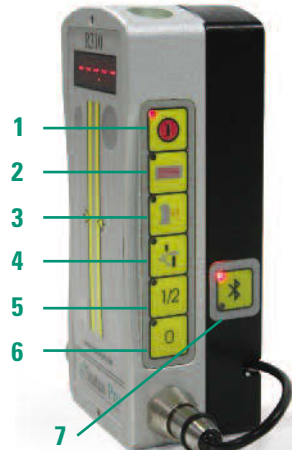

3.3 Setup Menu of the R310:







Repeated pressing of the Menu button(4) enables scrolling through the points of the Set-up Menü. The Set LEDs (C) signify whether or not a parameter or position has been activated. With some of the Menu parameters it is only possible to choose one or the other position. These Menu positions are marked in green in the following table:

Display	Indication	Description
POS X	POS X	Laser X -axis will be remotely controlled
POS Y	POS Y	Laser Y- axis will be remotely controlled
POS Z	POS Z	Laser Z- axis will be remotely controlled
RC 310	RC 310	IR signal solely for the R310 remote control
AG Lo	AG Lo	Averaging Low: low rate of averaging, quick reacting display
AG Hi	AG Hi	Averaging High: high rate of averaging, slower reacting display
NEAR	Near	Distance between Laser and Sensor < 25m
FAR	Far	Distance between Laser and Sensor > 25m
CAL X	CAL X	Calibrate X: Calibration of the T330 X-Axis at the present value
CAL Y	CAL Y	Calibrate Y: Calibration of the T330 Y-Axis at the present value
CAL Z	CAL Z	Calibrate Z: Calibration of the T330 Z-Axis at the present value
V 75	V XX.X	Volt: Display of the remaining battery power
C 22.2	C XX.X	Celsius: Internal Temperature of the R310
EU	EU	European or Metric System (Display in Millimeter)
US	US	Imperial System (Display in Inch)
IR 310	IR 310	Communication with T330 Laser over Infra-red
Cb 310	Cb 310	Communication with T330 Laser using a cable
AA600	XX8.88	Software version

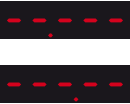
To set a desired point in the menu, press the Set button (6) , the symbol “set” appears in the display signifying confirmation.

To leave or exit the menu, press the ON / OFF button (1).

3.4 Display features of the R310:

Display	Description
	After turning on the R310 sensor, the present remaining battery power is automatically displayed.
	This symbol means that the sensor is turned on and ready, but no Laser beam is reaching the sensor. The decimal point displays which measuring Unit has been chosen: Second from left= Inch. Third from left = Metric.
	If the display was turned off using the Display button (2) and then turned back on again, all the segments in the display will be visible during the short display self-test.
	This symbol is visible when a parameter or point within the menu has been set or activated (Set button (6)).
	After pressing the ON/OFF button during operation the word „sleep” will be shortly displayed before the sensor switches off.
	When the remaining battery power falls below a preset threshold, the word bAtt will be visible. Around 30 minutes time will remain to change batteries.
	If the ambient temperature is too high or too low this symbol will appear. (Measurement Range: -10°C bis +50°C)
	When „Error” is visible, the sensor will turn itself off and then back on again. If the sensor is no longer serviceable please contact the customer services at Status Pro Systems.

4. Measurement

4.1 Signalling

All Information concerning the measurement and status of the R310 is shown in the display. When no laser is being detected, the „-----“ symbol will be displayed.

If a laser beam is being detected, the actual measurement value will be displayed. The value depicts where the rotating laser beam is in relation to the „Zero“ of the sensor. If the sensor is higher than Zero, a positive value will be shown, if the sensor is lower than Zero, a negative value will be shown.

Additionally, the Position LEDs(C) show if the laser beam is above or below Zero.

If the laser beam is within +/- 0.1mm of the Zero, both LEDs will blink. This feature is useful when aligning the laser to a reference line over greater distances where the actual measurement value is not visible.

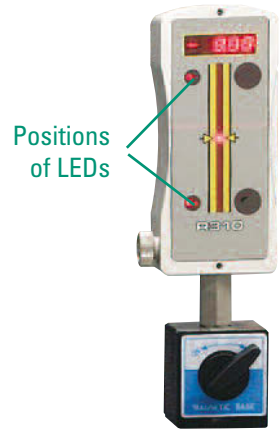

4.2 Distance and Averaging

The R310 has been designed to be able to operate under different conditions. For different operating ranges between Laser and sensor, choose one of the following parameters in the Menu: **nEAR** (Near) or **FAR** (Far). To change the rate or Averaging, choose one of the following from the Menu: **AV Lo** (Low Averaging) , or **AV Hi** (High Averaging).

Example I: Distance between Laser and Sensor less than 25m. Average ambient temperature and no air turbulence. In this case activate the following Parameters: **nEAR** and **AV Lo**.

Example II: Distance between Laser and Sensor less than 25m, high air turbulence and/or fluctuating temperature conditions. In this case activate the following Parameters: **nEAR** and **AV Hi**.

Example III: Distance between Laser and Sensor greater than 25m, average ambient temperatures and no air turbulence. In this case activate the following Parameters: **FAR** and **AV Lo**.

Example IV: Distance between Laser and Sensor greater than 25m, high air turbulence and/or fluctuating temperature conditions. In this case activate the following Parameters: **FAR** and **AV Hi**.

If the following Mode **RG H.** has been selected from the Menu, the display will react quite slowly due to the **high rate of averaging**. If, on the other hand, **RG Lo** has been activated, the display will react almost immediately when the sensor is moved, due to the **low rate of averaging**; which is useful when adjusting machines.

4.3 Remotely controlling the Laser using Infra-red

The R310 can transmit signals using Infra-red (IR) when needed, allowing remote controlling of the T330 Rotational Laser and/ or the sending of information to the RC310 Remote Control.

To initiate the remote movement of the T330 Laser, press the Infra-red IR button  (3) on the keypad of the R310 Sensor, and the Laser will automatically move towards the Zero position on the R310 sensor in either the X-Axis or the Y-Axis depending upon which axis has been chosen from the Menu; either **Pos X** or **Pos Y**. When the Zero position has been reached, the Laser will be held in this position as long as the Infra-red button is activated. To "release" the Laser, press the Infra-red button again.

If the **rc310** command has been activated in the Menu, the R310 will send an Infra-red signal containing the present sensor measurement value to the RC310 Remote Control . This signal is invisible to the T330 Laser.

4.4 Achieving a level plane using Infra-red

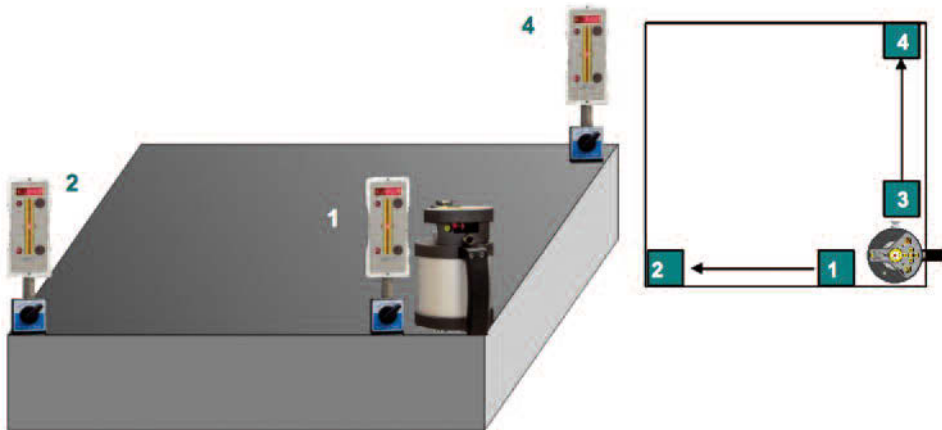

- 1) Place the R330 on the object to be measured, ensuring sight at all four sensor positions.
- 2) Turn on the T330, activate the rotation and the self-levelling functions.

- 3) Place the R310 sensor with magnet mounting directly in front of the T330 Laser (1) and press "Zero" on the sensor.
- 4) Move the R310 sensor to the distant end of the plane (2). Ensure the R310 sensor is adjusted to control the "Y" axis as follows: Using the Menu button, scroll through the Menu until you reach Pos Y. Set this Axis by pressing the 0 button on the sensor. Exit the Menu by pressing the Power On/Off button on the sensor, then finally, press the Infra-red button on the sensor. The laser plane will be automatically „pulled down“ to Zero (0) in this plane. When the value has reached zero(0) disable the Infra-Red function by pressing the IR button on the sensor.
- 5) Move the R310 sensor close to the T330 Laser in the plane at 90 Degrees from the Y Axis(3) and press the Zero button on the sensor. Align the IR mirror on the T330 towards the R310 sensor. Set the IR controlling of the X-Axis as follows: Using the Menu button, scroll through the Menu until you reach Pos X. Set this Axis by pressing the 0 button on the sensor. Exit the Menu by pressing the Power On/Off button on the sensor. Place the sensor at the distant end of the X-Axis (4) and finally, press the IR button on the sensor. The laser beam will be automatically „pulled down“ to Zero (0) in this plane. When the value has reached zero(0), disable the Infra-Red function by pressing the IR button on the sensor.

4.5 Measuring objects of different height

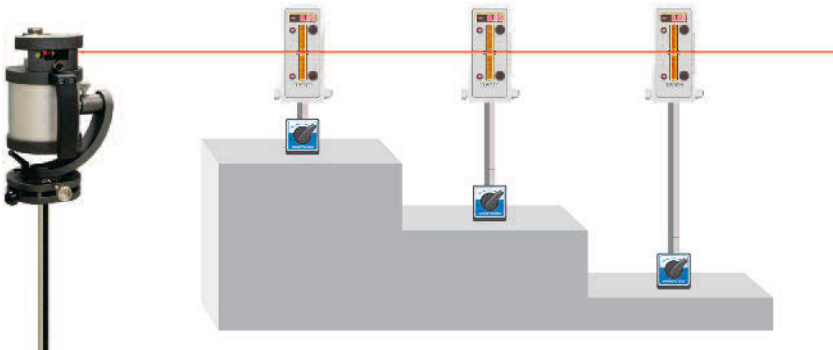

Sometimes when levelling, objects of differing height have to be measured in relation to each other. To enable this, use spacers (FIX 1-0658) placed between the magnet and the M8 Adapter. Typically, you would manufacture the spacers to the exact height difference between the objects, enabling a "Zero" reading when the goal is reached.

4.6 Checking and calibrating the self-levelling feature of the T330 Laser

After being transported it makes sense to check, and if necessary, re-calibrate the levelling exactness of the T330 Laser before attempting an exact measurement.

Checking the calibration of the T330 Laser

1. Mount the T330 und R310 at a distance ideally between 5 & 10m, then switch both on.
2. Press the Self Levelling button on the T330.
3. "Zero" the value on the R310 using the  keypad button.

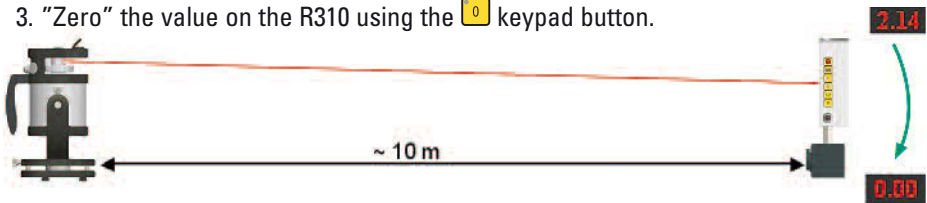

4. Turn the T330 through 180°. If necessary reactivate the Self Levelling on the T330.
5. The value now shown on the R310 is the doubled Levelling error.
6. Halve the value shown on the R310 by pressing  button on the R310 keypad to receive the Level error to be corrected.

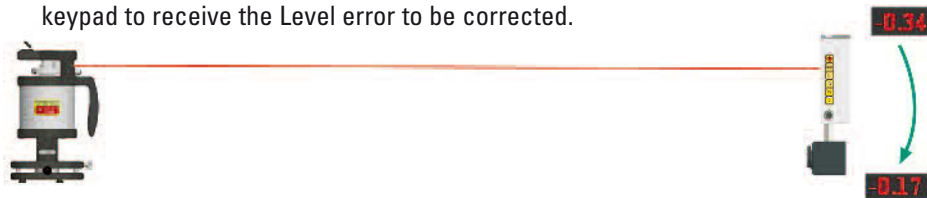



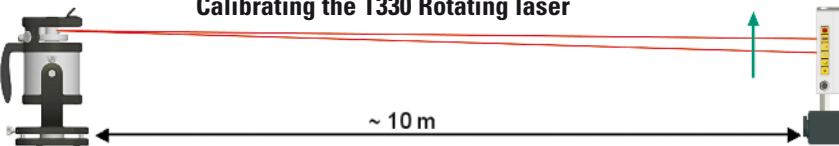

The value now shown on the R310 can be divided by the distance in metres between Laser and sensor to obtain the levelling exactness in mm/metre (should be better than 0,025mm / 1000mm) You can now assess if your Laser is up to the task at hand.

If the Laser needs to be calibrated, continue as follows:

Calibrating the T330 Rotating laser



7. Activate  in the R310 Menü (Y-Axis).
8. Press the Infra-red button  (3) to establish communication between Laser and Sensor and to initiate remote movement of the Laser towards "Zero".

9. When the T330 has reached Zero (0) enter the R310 Menu and search for the  Feature.
10. To complete the calibration process for this particular Axis, press the 0-Button  (6). The T330 confirms the calibration by a beep signal and stopping the rotation of the laser beam.
11. Repeat the test procedure for the other Axis, (X or Y) and calibrate if necessary.

**Note**

This test solely for checking the self-Levelling of the T330 Laser. All other tests and checks are carried out before delivery and within the designated service intervals by Status Pro personnel (R&K).

5. Technical Details

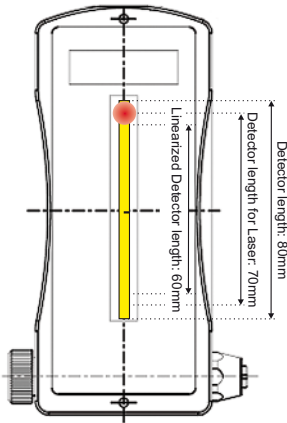

Intensity distribution at 4 m distance:
 Laser beam diameter at 1% intensity: 0,7 - 8,0 mm
 Beam circular Error: < 0,1%

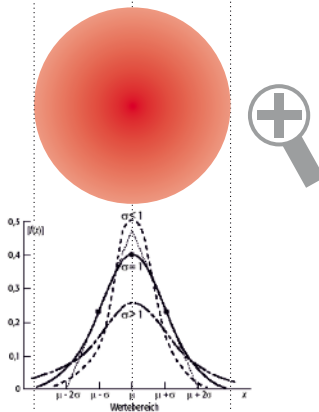

Display:	7 Segment LED
Sensor:	80 mm Diode array
Resolution:	0.01 mm
Accuracy:	± 0.02 mm+ 1% non-linearity
Temperature resolution:	0,1°C
Voltage resolution:	0,1 V
Range:	typical: 50 m
Protection class:	IP 54
Housing:	Aluminium
Weight:	680 g (425 g without battery compartment)
Dimensions (w x h x d):	65 x 150 x 48 mm (65 x 150 x 24 mm without battery compartment)

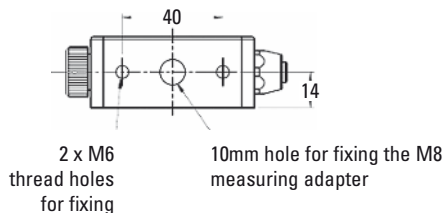
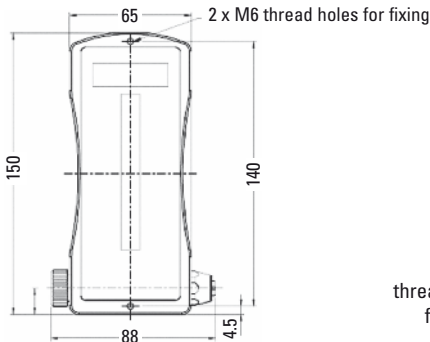

6. Accesories



Power Supply Cable (BT 800066)

Mains cable for use with the T310/T330 and R310. The cable assembly is supplied with a wide range of adapters for use worldwide and is CE Certified.



Battery Compartment with Bluetooth for R310 (BG 830135)

Bluetooth kit for upgrading a R310 Laser Receiver. Ideal for flange measurements, and in places not suitable for working with cables. Complete with rechargeable battery and charger.



Battery Compartment without Bluetooth for R310 (BG 830136)

Accessory for a R310 Laser Receiver, complete with rechargeable battery and charger.



Battery Pack for Laser Receiver R310 (BT 800071)

Battery Charger for BT 800071 (BT 800072)

External battery charger for batteries of the Laser Receiver R310.



Remote Control for T330 and R310 Monitor

(BG 830930)

Remote control for the T330, Remote Display of current R310 values.



Floor and Wall Mounting Console (BG 830119)

Using the floor mounting console, the R310 Sensor can be aligned exactly over a Centre Line using the centring spike. Levelling of the Sensor is possible using the mounted spirit level.

Alternatively, the console can be used as a wall mounting. There are several drillings as well as threaded holes enabling easy fixing. A 5/8 inch thread enables mounting using a tripod.

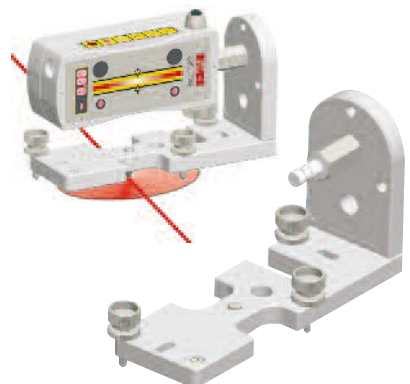



Tape Measure Incremental (BT 989045)

The Tape Measure has been modified specially for use with the Floor and Wall mounting console. The tape has a punched hole every 100mm enabling the attachment of the measure to the console.

This features simplifies the moving or offsetting of a centreline.



Prism magnet base, switchable (BT 943092)

The magnet has an M8 Thread on the top side for the Measuring adapter thus providing a solid mounting or the R310 Sensor on any magnetic surface. The base is finely ground giving high reproducibility when measuring.

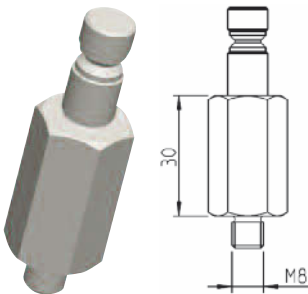

Measuring Adapter M8 (BT 948336)

The Measuring adapter provides the mounting for the R310 Sensor. The M8 thread enables fixing of the Sensor on machine parts to be measured or using the magnet base as a mobile Mounting.

Extensions for Adapter M8

- 80 mm (FIX 1-0658-080)
- 300 mm (FIX 1-0658-300)
- 600 mm (FIX 1-0658-600)



Block magnet with probe tip (BG 830175)

The probe tip acts as an extension of the R310 Sensor enabling exact measurements of points within a measurement grid. The magnet ensures a vertical and therefore reproducible mounting on the measurement object.



Block magnet with spring-loaded probe tip (BG 830195)

The probe tip acts as an extension of the R310 Sensor enabling exact measurements of points within a measurement grid. The magnet ensures a vertical and therefore reproducible mounting on the measurement object. The spring facilitates a permanent contact of the probe tip with the measurement surface even when working upside down.



Display unit DU 320 (IT 200410)

Display unit / ultramobile – PC based. For industrial use; with protectors, internal and external battery and bluetooth.





Status Pro Maschinenmesstechnik GmbH
Mausegatt 19
D-44866 Bochum
Phone: + 49 (0) 2327 - 9881 - 0
Fax: + 49 (0) 2327 - 9881 - 81
www.statuspro.com
info@statuspro.com

Distributor