

R545

Laser Receiver

User Manual



User Manual – English

Laser Receiver R545 (SP R545-P)

We would like to congratulate you on the purchase of your Status Pro R540 Laser receiver. Before initial usage you should carefully read the safety instructions as well as the user guidelines contained in this manual. We wish you every success when using this Measurement Instrument.

Please note: User Manuals can be amended when improvements or changes to the product range have been carried out. Use the link below to make sure you have the most up to date version of your User Manual: www.statuspro.com

Content

- 1. SAFETY INSTRUCTIONS 3**
 - 1.1 Class of Laser 3
 - 1.2 Standards 4
 - 1.3 Advice on batteries / rechargeable cells 4
 - 1.4 Instrument Care 5
 - 1.5 Maintenance 5
 - 1.6 Calibration 6
- 2. GETTING STARTED 7**
 - 2.1 Power Supply 8
 - 2.2 Assembly 9
- 3. OPERATION 10**
 - 3.1 Operational elements of the R545 10
 - 3.2 Measuring using the R545 11
- 4. TECHNICAL DATA 12**
- 5. ACCESSORIES 14**
- 6. PRODUCTS AND SERVICE 18**

1. Safety Instructions

1.1 Class of Laser

The laser light emitted from a Status Pro Laser has an Output Rating of $< 1,0$ mW. The Laser is placed in the category "Class 2" and is classified as safe for the use as a Measurement Instrument. There are however a few safety aspects to be observed:



Caution!

- Do not stare into the laser beam.
- Do not point the laser beam at other people.
- Observe the local safety guidelines on Site and if in doubt consult the Site safety engineer.
- Do not use the equipment in damp or moist locations.
- Ensure shading of the equipment against direct sunlight or heat sources.
- Fluids or rain as well as extreme temperature conditions may damage the equipment.



Note

Do not violently shake the Laser or other sensors and always protect against falls. This can damage the structure or the optics of the instrument resulting in false measurements.
Do not touch rotating parts when in use!

1.2 Standards

Status Pro Laser and Receiver Instruments are developed and manufactured according to the following CE Standards:

- EN 55 011
- EN 55 022
- EN 61 000-4-2
- EN 61 000-4-3
- EN 60 335



1.3 Advice on batteries/rechargeable cells

If the equipment is being stored for a longer period of time or being powered using Mains, then the batteries should be removed to prevent damage of the instrument through leakage. When using rechargeable cells always observe the specific charging procedures for the cells. Rechargeable cells can be recharged around 1000 times when treated correctly, but there is no guarantee!



Caution!

Do not try to recharge normal batteries. Do not expose batteries or rechargeable cells to fire or excess heat (Danger of explosion).
Do not mix batteries and rechargeable cells.
Always use batteries and cells of the same kind.
Do not mix old and new batteries or cells.



Note

Help to protect the environment! Empty batteries do not belong in the household waste disposal system. Only deposit empty or damaged cells at a collection point specially designed for this purpose.

1.4 Instrument Care

Your measurement instrument is designed for use in an industrial environment and can withstand water splashes or light spray as well as dust. Clean the equipment using a soft cotton cloth and a mild soap solution. Laser apertures as well as sensor areas should only be cleaned using a soft, dry and dust-free cloth. Do not use paper towels to clean glass surfaces as they could scratch. Avoid contact with grease, oil or oil-based solutions when handling the equipment.

1.5 Maintenance

The mechanical components of your equipment are prone to natural wear and tear! If the Instrument appears to have a technical defect, contact the Manufacturer. Do not try to repair or open the sensor casing. Attempted repairs through unauthorised personnel makes the guarantee null and void! Always store the equipment under dry conditions and use the case for transportation.

To ensure trouble-free processing, simply fill in the form you will find using the following link:

www.statuspro.com/machine_geometry/service_support/calibration_repair/



Advice

To be able to identify the equipment when seeking advice always quote the serial number of the equipment. The Manufacturer does not accept any responsibility for damage incurred through incorrect maintenance carried out by non-authorised personnel.

1.6 Calibration



To guarantee measurement accuracy and reliable operation of your Status Pro Measurement System, it is of utmost importance that the recommended Service Intervals be adhered to. The System should be checked for serviceability, and re-calibrated by the Status Pro workshops every 12 months.

Within the scope of the service checks, the complete system will also be examined for possible wear or damage, as well as receiving any software updates. The date of the next service check for your equipment is stamped on the Status Pro calibration sticker.

To ensure trouble-free processing of the service and calibration checks, simply fill in the form you will find using the following link:

www.statuspro.com/machine_geometry/service_support/calibration_repair/

1.7 Liability Exclusion

The Status Pro GmbH does not accept responsibility for damage incurred through incorrect use or handling of the equipment. To ensure correct usage, a founded knowledge of the equipment is essential. It is of the utmost importance that you read and understand the User Manual!

No responsibility will be accepted for damage incurred through ignorance or disregarding of the operating instructions.

2. Getting Started

The SP R545-P Package consists of the R545 Laser Receiver (I – BG 830450), a re-chargeable Li-Ion power pack (II – BT800071) and the external battery charger (III – BT800072).

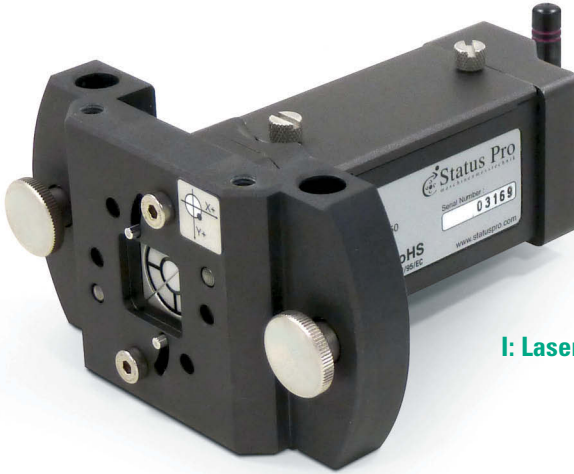

I: Laser Receiver R545



II: Li-Ion Power Pack



III: Battery Charger

2.1 Power Supply

The R545 is powered using a rechargeable Li-Ion battery pack, which can be exchanged when exhausted. Fully charged the power pack will supply enough energy for around 8-10 hours of use.



On the upper side of the R545 there are two (captive) knurled screws which secure the battery cover. To access the battery compartment, unscrew the two knurled screws and remove the cover. To remove the battery, simply lift the battery from the front side of the sensor and then remove completely.



Take care when inserting a battery pack into the battery compartment that you are inserting in the correct way. If you have to use force when inserting the battery pack, then you are trying to insert the wrong way round, as the battery only fits in the one way.

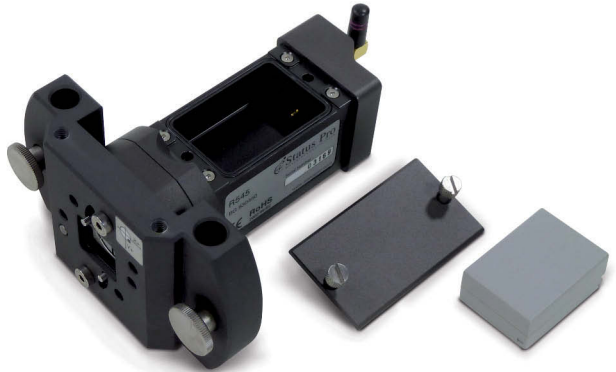

The battery pack can only be charged after removing from the sensor! The battery can only be charged using the supplied external battery charger (BT 800072).

A complete charging process using the charger (BT 800072) takes approximately 1 hour. During the charging process the LED at the rear of the sensor is lit up orange, and when the charging process is completed, the LED colour will change to green.

The supplied charger is capable of recognizing the charge condition of the battery pack, therefore an "over-charging" of the battery with this charger is not possible.

2.2 Assembly

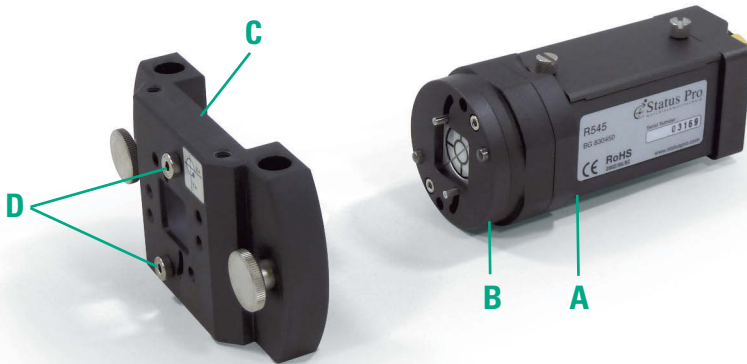

The R545 consists of the housing (A) with a circular collar (B) and an Adapter Plate (C).

The R545 Adapter Plate can be dismantled for sensor use with other adapters by simply removing the 2 allen screws (D) at the front side.

The Adapter Plate facilitates the mounting of the R545 Sensor on diverse objects with the aid of the Mounting Rods (E). The Mounting Rods (E) are optionally available in 3 lengths and can be fitted to the bridge on the magnet as required. The rods are available in three lengths of 60, 80 and 150 mm (BT 948155, BT 948156, BT 948157).



3. Operation

3.1 Operational elements of the R545

Front side

The actual sensor is situated behind the protective shutters (1), which are also useful when carrying out coarse alignment of the laser beam. Open the shutters using the two pins (2). The “co-ordinate sticker” (3) is a useful aid when interpreting a measurement value.

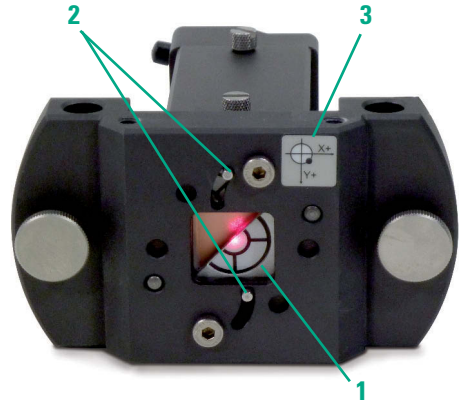

Rear side

The Bluetooth Antenna (4) enables wireless communication between Sensor and PC. Turn on the R545 sensor by pressing the Power button (5), turn off by pressing and holding for 2 seconds.

The Blue-Tooth LED (6) supplies information over the connection status:

- Constant blue: Bluetooth connection with the UMPC is established
- Intermittent blue: Information over Bluetooth is being actively transferred

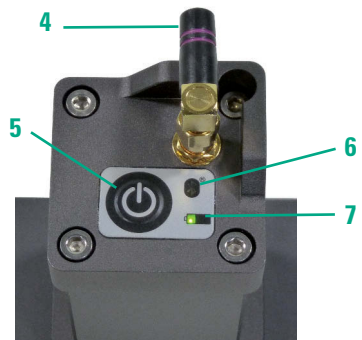

The Power LED (7) supplies information over sensor as well as the battery/charging status:

- Constant green: R545 is turned on and the Battery is charged
- Flashing green: R545 is turned on and the Battery is nearly exhausted

3.2 Measuring using the R545

Follow these simple steps to carry out a measurement using the R545:

1. Make sure the R545 is charged
2. Mount the R545 on a suitable adapter
3. Align the laser beam to hit the target cover of the R545
4. Open the target shutters
5. Turn on the R545
6. Establish BT connection between PC Software and R545
7. If necessary, finely adjust the laser beam using the Software
8. Measure at will

After completing a measurement, close the shutters over the lens to prevent damage or soiling!



Note

Be sure to attend correct training in the usage of your equipment either at Status Pro in Bochum, or within your own company. Only after being thoroughly trained are you able to use the equipment to the best of its capabilities and to fit your measurement requirements!

4. Technical Data

Display:	Measurement displayed over Display Unit / PC	Protection Class:	IP 54
Measurement range:	20 x 20 mm minus the Laser-Ø	Housing:	Aluminium, anodised
Resolution:	1 µm	Weight (without Battery):	408 g
Measurement uncertainty:	±1 µm/m + 1% Sensor nonlinearity	Weight (with Battery):	452 g
Laser Wavelength:	650 nm / modulated	Weight (with Battery and mounting plate):	706 g
Interface:	Bluetooth Class 2 (Range up to 50 m)	Dimensions without mounting plate (B x H x T):	60 x 60 x 143 mm
Power supply:	7,4 V Li-Ion Battery Pack, exchangeable	Dimensions with mounting plate (B x H x T):	119 x 68 x 149 mm
Battery operating time:	> 8 Hours		

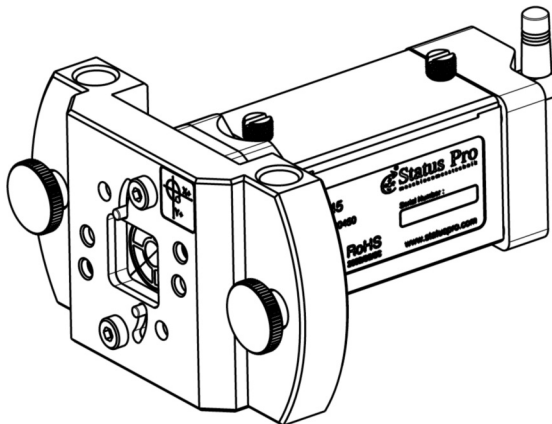

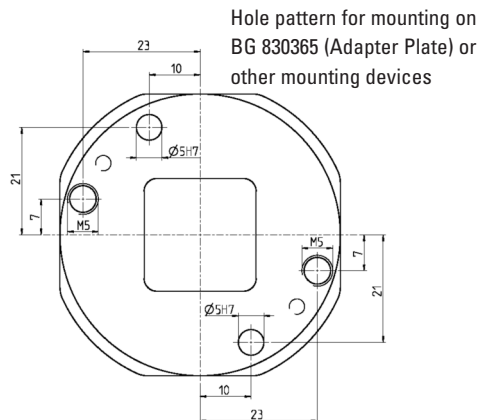
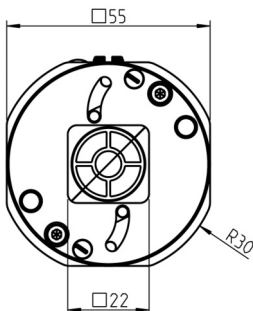
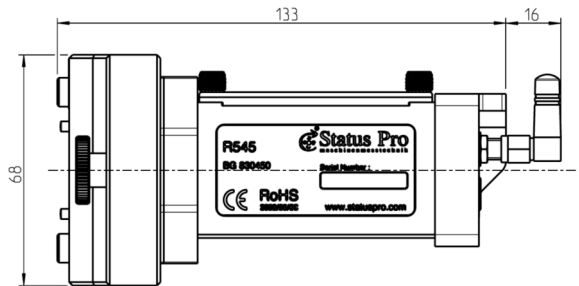
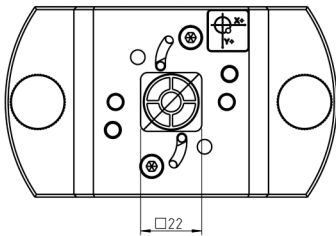
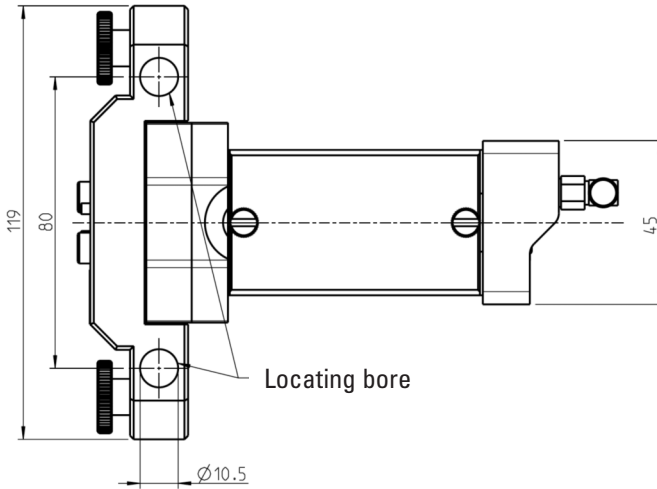

5. Accessories

Li-Ion Battery (BT 800071)

For the Laser Receiver R280/R310/R540/R545



Battery Charger (BT 800072)

for the Li-Ion Battery BT 800071



Magnet Attachment (BG 830315)

Switchable magnet with bridge for fixing mounting rods from 60 mm up to 150 mm Length and 10 mm Diameter (BT 948155, BT 948156, BT 948157). The R525 is mounted over the rods and fixed at the desired height using the two knurled screws.





Mounting Rods

BT 948155: 60 mm Long, 10 mm Diameter
 BT 948156: 80 mm Long, 10 mm Diameter
 BT 948157: 150 mm Long, 10 mm Diameter
 Mounting rods for use with Magnet
 BG 830315, or other adapter assemblies.
 Use several rods together to gain height.



Roll Adapter (FIX 2-0363)

This Adapter facilitates mounting of the R545 Sensor when measuring Cylinder or Roll Parallelism. Use with Mounting rods of 60 up to 150 mm Length and 10 mm Dia - meter (BT 948155, BT 948156, BT 948157).



T250 Laser Source (SP T250-P)

T250 Package comes complete with Power Supply Cable and Adapter for use with the Borealign Package or for use with a Tripod. The Laser beam is adjustable in offset and in angle. Perfect for measuring straightness, or for measuring bearing ways in engines for example.

Software ProLine V3 (SW 200103)
Professional Software for Linear Measurements.

Software ProOrbit V3 (SW 110020)
Professional Software for measuring Boreways etc.

Software ProRoll V2 (SW 110050)
Professional Software for measuring parallelism.

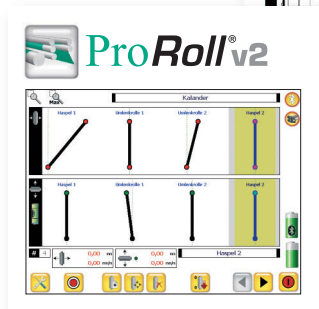
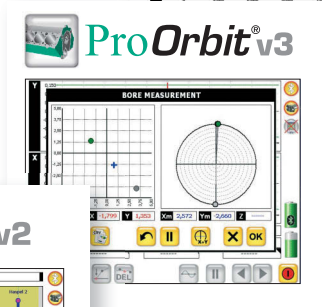
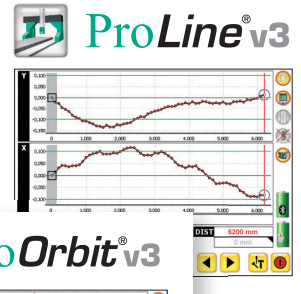

Display Unit DU 320 (IT 200410)
Display unit / UltraMobile-PC.
For industrial and field use; with rubber protectors, internal and external battery with "Hot-swap" feature.
Communication over USB and Bluetooth.



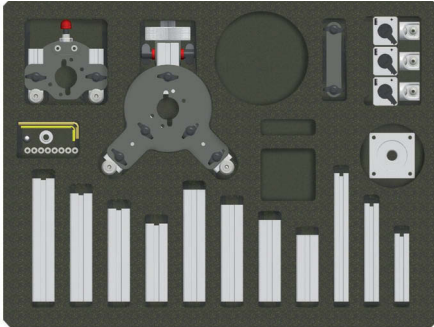

Bore-Align Kit (SP BOREALIGN)

Attachment Kit for measuring bore-ways.

The set provides measurement capability of measurement from 60 mm up to 1200 mm. Attachment of the Laser Transmitter T250 and the Laser Receiver R545 is possible; in, in front of and behind the bore-ways. The sensor is mounted in a spring-loaded attachment giving "4-point" contact on the measurement surface.



Tripods for the Lasers and/or Sensors

(The stated laser height is the height of the beam when the T330 Laser is mounted on the Tilt/Swivel Adapter and in the prone/laying position.)

SP Stativ 005-P:

Laser Height 260 mm – 540 mm

Weight 2,1 kg

Stativ 01-P:

Laser Height 815 mm – 1205 mm,

Weight 5,5 kg

Stativ 1.5-P:

Laser Height 1030 mm – 1970 mm,

Weight 12 kg

Stativ 02-P:

Laser Height 1140 mm – 2170 mm,

Weight 12 kg

Stativ 03-P:

Laser Height 1430 mm – 2790 mm,

Weight 13 kg

Stativ 04-P:

Laser Height 2150 mm – 4180 mm,

Weight 19 kg



6. Products and Service

Geometrical measurement techniques and alignment have been an issue since the pyramids.

Today the measurement and alignment of machinery components is an integral part of the assembly and quality control process. Be it linear guides, presses, flange connections, drive shafts or cylinder rolls, the precision of the alignment has a significant effect on the functionality of the component. The alignment of these machinery components will often affect the quality of the manufactured product and also the life-time of the machine components themselves. The use of a laser beam reference together with tradition industrial-measurement techniques has made it possible to build tools which simplify these alignment procedures.

Status Pro develops and manufactures laser alignment equipment and we are committed to this process.

Most of our customers are machine builders, assembly and quality control people. Typically our customers require a complete solution package including on-site training and support. When a customised solution is required, modifications are often necessary, be it in software, mechanical adaptations or the sensor housing itself in order to meet customer requirements.

We and our partner companies all over the world also provide alignment and industrial surveying services.

We invite you to visit our web site www.statuspro.com
For more information just call us at + 49 (0) 2327 – 9881 – 0



7. Memo

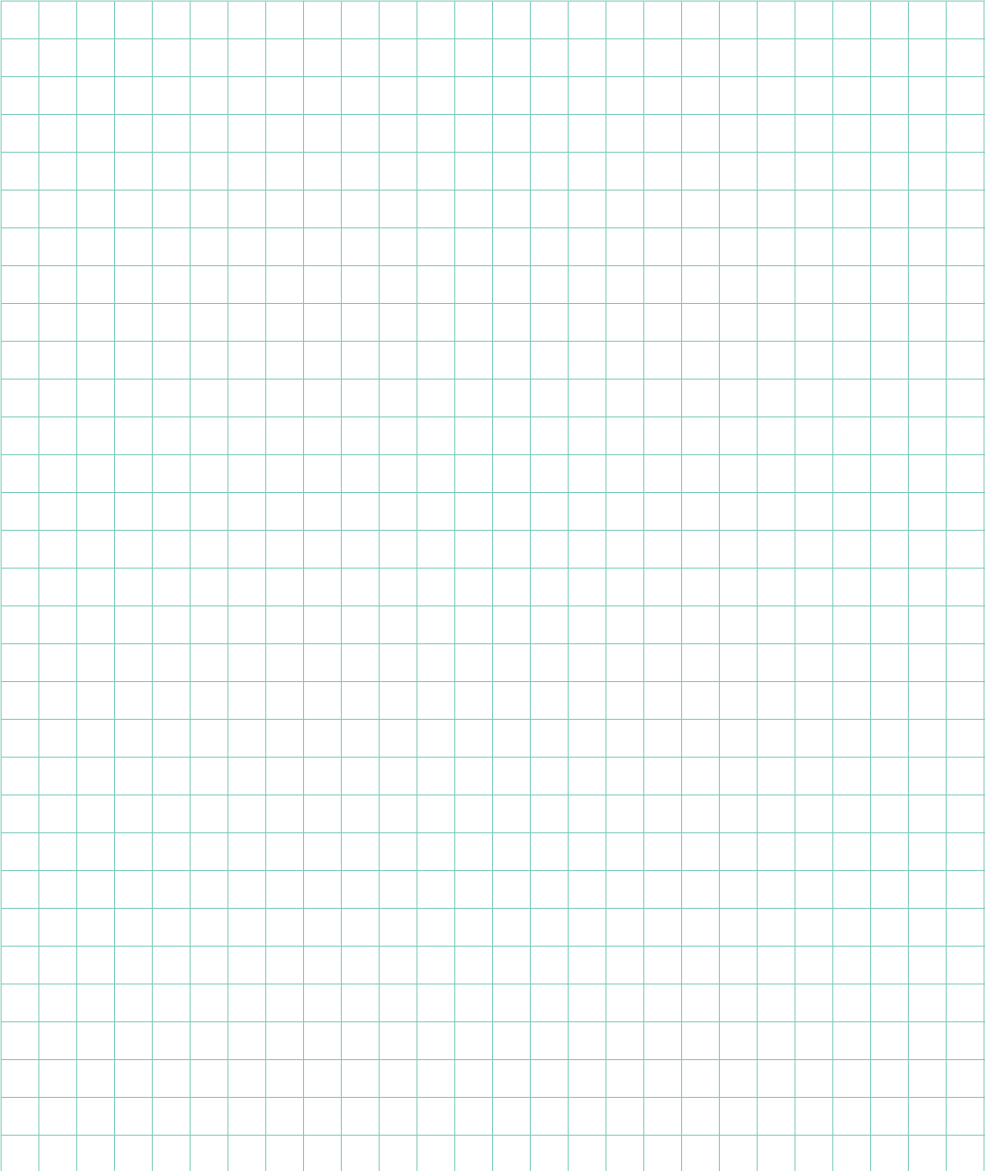



Status Pro Maschinenmesstechnik GmbH
Mausegatt 19
D-44866 Bochum
Telefon: + 49 (0) 2327 - 9881 - 0
Fax: + 49 (0) 2327 - 9881 - 81
www.statuspro.com
info@statuspro.com

Distributor